

Linear Guideway (BRH-C & CL - Through Hole type with Flange)

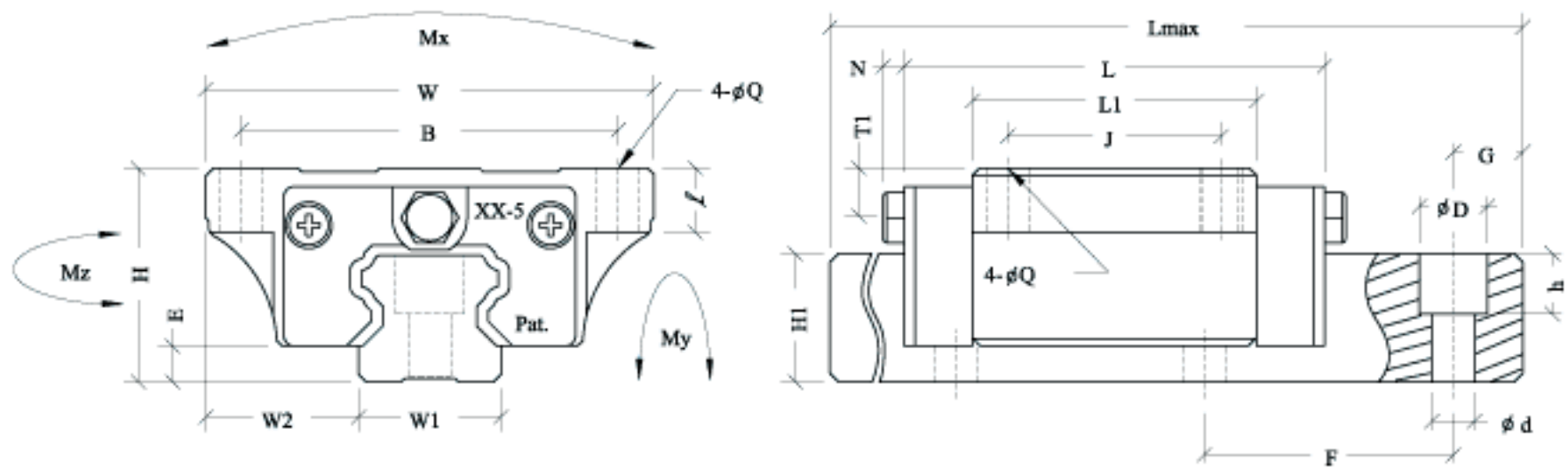

Model No.	Assembly (mm)				BR block (mm)							BR rail (mm)			
	H	W	W2	E	L	B x J	φQ x ℓ	L1	Oil hole	T1	N	W1	H1	F	d x D x h
BRH15C	30	63	21.5	5	77.8	53X40	φ4.5X8	48.8	M6X1	5	6.5	20	18	60	6X9.5X8.5
BRH20C	30	63	21.5	5	77.8	53X40	φ6X9	48.8	M6X1	5	6.5	20	18	60	6X9.5X8.5
BRH20CL					92.4			63.4							
BRH25C	36	70	23.5	7	88	57X45	φ7X12	57	M6X1	5	6.5	23	22	60	7X11X9
BRH25CL					110.1			79.1							
BRH30C	42	90	31	9	109	72X52	φ9X12	72	M6X1	7	6.5	28	26	80	9X14X12
BRH30CL					131.3			94.3							

Model No.	Ref. Data		Basic Load Rating (kgf)		Static Moment (kgf*m)			Weight	
	Lmax	G	Dynamic load rating	Static load rating	Mx	My	Mz	Block (kgf)	Rail (kgf/m)
BRH15C	4000	20	850	1650	10	8	8	0.19	1.4
BRH20C	4000	20	1450	2560	22	18	18	0.4	2.6
BRH20CL			1900	3330	28.6	23.4	23.4	0.52	
BRH25C	4000	20	2140	4000	36	32	31	0.57	3.6
BRH25CL			2996	5600	50.4	44.8	43.4	0.72	
BRH30C	4000	20	2980	5490	60	50	49	1.1	5.2
BRH30CL			3900	7190	78.5	65	65	1.4	